

Pipe fixing system

7 Pipe fixing system

7.1 Choice of pipe fixing system

The choice of the pipe fixing system is essential to correctly install the pipe system. Depending on the temperature of the medium, the ambient temperature and the building constraints there are the following options:

- 1 Installation in guide brackets with correction for axial movement of the pipe by means of:
 - Snap-expansion sockets
 - Deflection leg
 - A combination of both
- 2 Rigid installation
- 3 Embedded in concrete
- 4 HDPE systems below ground

7.2 Installation in guide brackets

With compensation for axial movement of the pipe with snap-expansion sockets

The axial movement is caused by the linear expansion of the pipe. The total expansion Δl triggered by the temperature difference can be calculated using equation 7.1 or can be taken from graphic drawing 7.1.

$$\Delta l_t = L_{\text{pipe}} \cdot \alpha_t \cdot t_{\text{max}} \cdot 10^3$$

Equation 7.1

Length change caused by temperature difference

Δl_t = Length change (mm)

L_{pipe} = Total length of pipe (m)

α_t = Linear expansion coefficient (mm / m³K)

t_{max} = Temperature difference in °C

The maximum length change which can be accommodated by the expansion sockets can be found in table 7.1.

d ₁ (mm)	Art. Nr.	Total length (mm)	Min. insertion depth 20°C (mm)	Max. expansion (mm)
32	40 03 20	130	74	56
40	40 04 20	132	76	56
50	40 05 20	132	76	56
56	40 56 20	132	76	56
63	40 06 20	132	76	56
75	40 07 20	132	76	56
90	40 09 20	134	78	56
110	40 11 20	134	78	56
125	40 12 20	135	79	56
160	40 16 20	140	84	56
200	40 20 60	230	120	110
250	40 25 60	250	125	125
315	40 31 60	270	126	144
75	42 07 20*	256	32	146
90	42 09 20*	256	33	144
110	42 11 20*	256	35	141
125	42 12 20*	256	37	139
160	42 16 20*	256	40	143

*expansion sockets without snap function

Table 7.1 Length change with expansion sockets

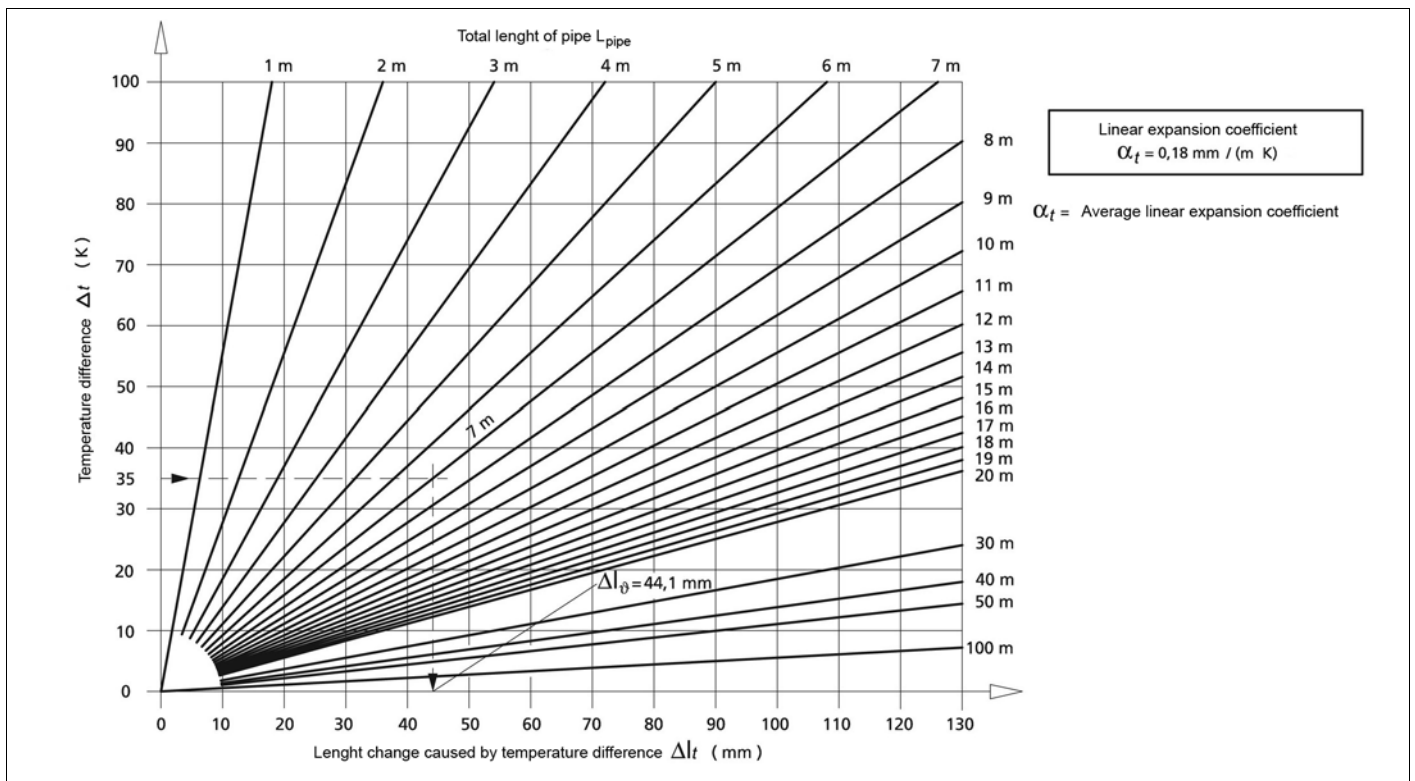

Graphic drawing 7.1 Length change caused by temperature difference

The general rule regarding the number of expansion sockets to be used is:

Every expansion socket can accommodate the expansion and contraction of a 5 m pipe. In every pipe section the required expansion sockets have to be installed. The number can be derived as follows (see example):

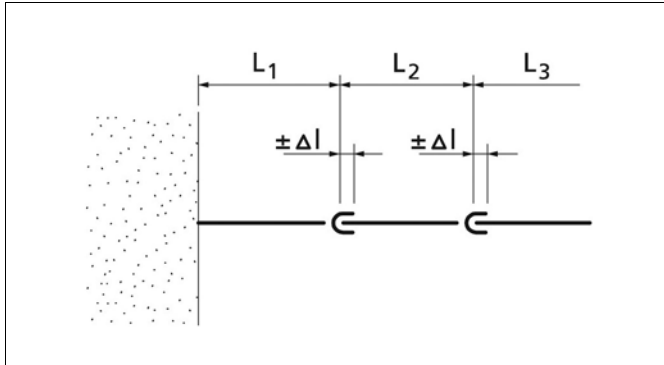

Illustration 7.1 Pipe section with expansion sockets

Example:

Length pipe section ($L_1+L_2+L_3$): 18 m

Installation temperature: 5°C

Temperature medium: +15°C / +75°C

Temperature difference: 75-5 = 70°K

Total expansion: 18 m x 0,18 mm/mK . 70K = 227 mm

In a pipe section of 110 mm diameter this results in $227/56 = \sim 4,1 = 5$ expansion sockets.

This general rule can be used for pipe sections of 5 m length and long term temperature differences $\leq 37,5^\circ\text{C}$.

With short term temperature differences, for example the emptying of a bathtub, a reduction factor of 0,5 can be applied to the temperature difference. In the example this would result in $0,5 \times 227/56 = \sim 2,1 = 3$ expansion sockets.

The general rules can be applied for pipe lengths ≤ 5 m in most drainage applications. With extreme high temperatures possibly in combination with a complex route the number of expansion sockets needs to be calculated.

7.3 Installation in guide brackets

With correction for axial movement of the pipe with a deflection leg

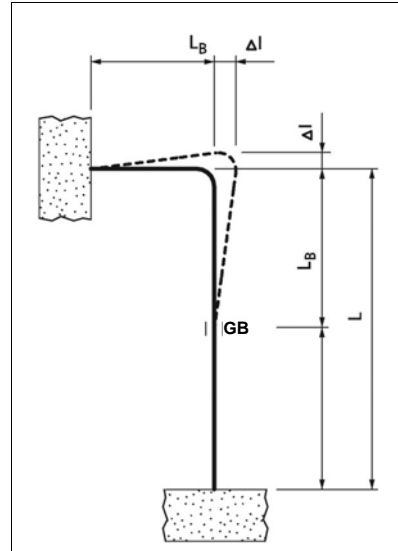

- L_A = Bracket distance
- L_B = Length deflection leg
- L = Pipe length
- GB = Guide bracket
- Δl = Length change

Illustration 7.2
Installation with deflection leg

For computing the length of the deflection leg the equation 7.2 can be used or graphic drawing 7.2 and 7.3, depending on temperature of installation and operation.

$$L_B \geq 10 \times \sqrt{\Delta l} \times d_{1,2}$$

Equation 7.2 Computing the length of deflection leg

- L_B = Length of deflection leg in mm
- d_1 = Diameter pipe
- Δl = Length change caused by expansion

First the length change Δl has to be determined at a temperature difference Δt_{max} (see paragraph 7.2).

Pipe fixing system

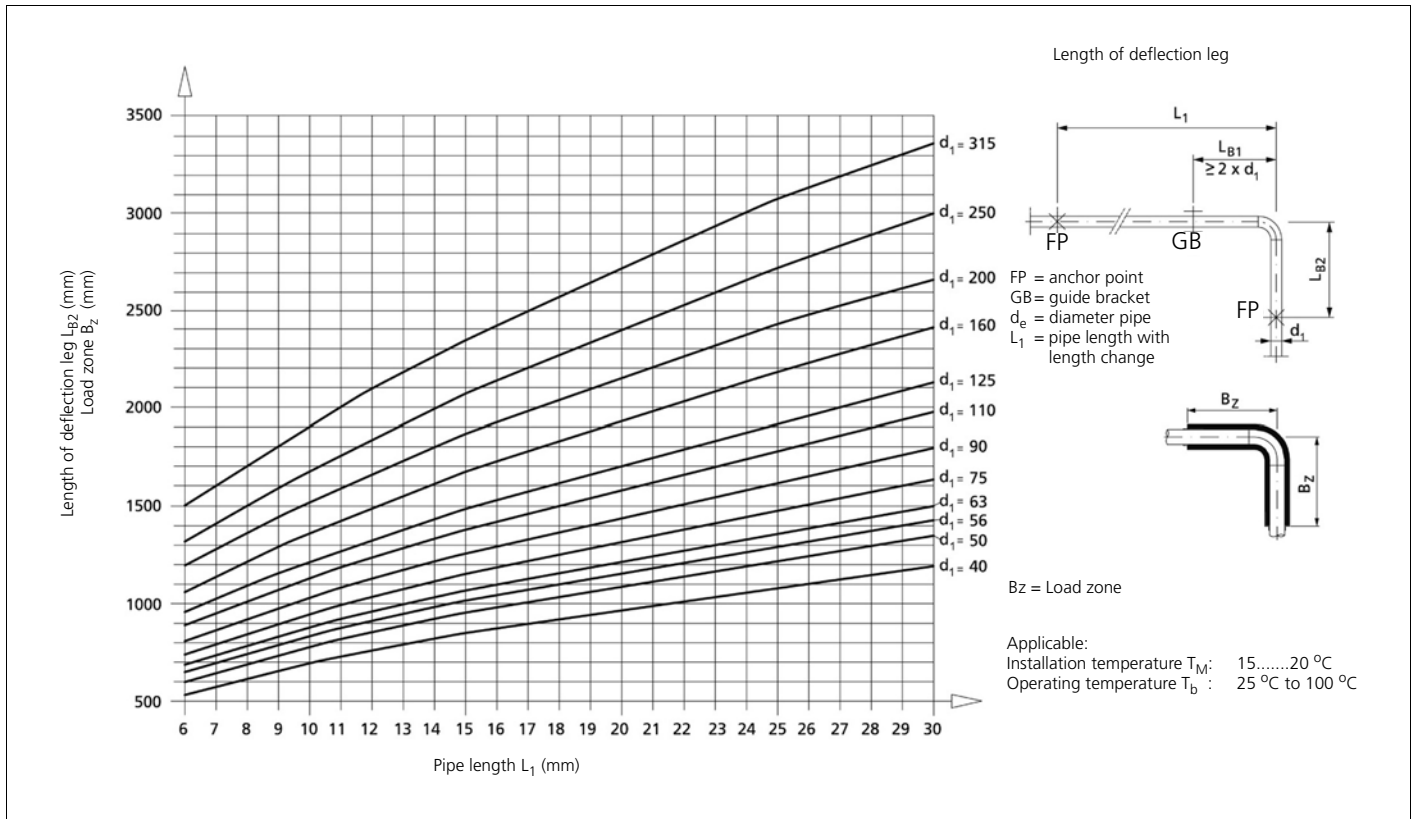

Graphic drawing 7.2 Length deflection leg at operating temperature 25°C - 100°C

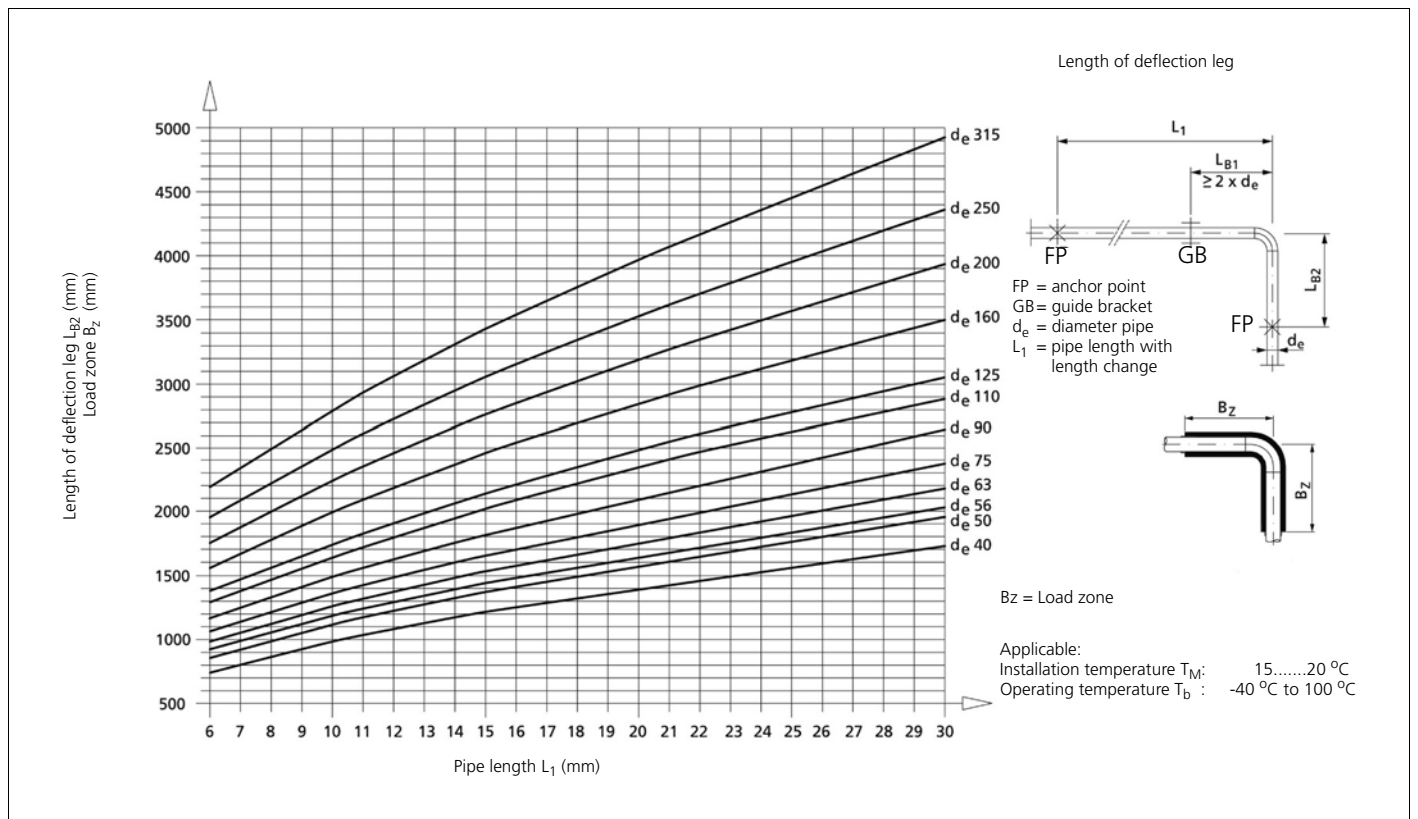

Graphic drawing 7.3 Length deflection leg at operation temperature -40°C - 25°C

Pipe fixing system

7.5 Rigid installation with anchor points

In some applications the Akatherm HDPE drainage systems can also be installed using the rigid installation method. The HDPE pipe is not free to expand and the forces caused by the expansion will be transferred completely to the brackets. Because of the forces and resulting tensions in the pipe, the applications are limited.

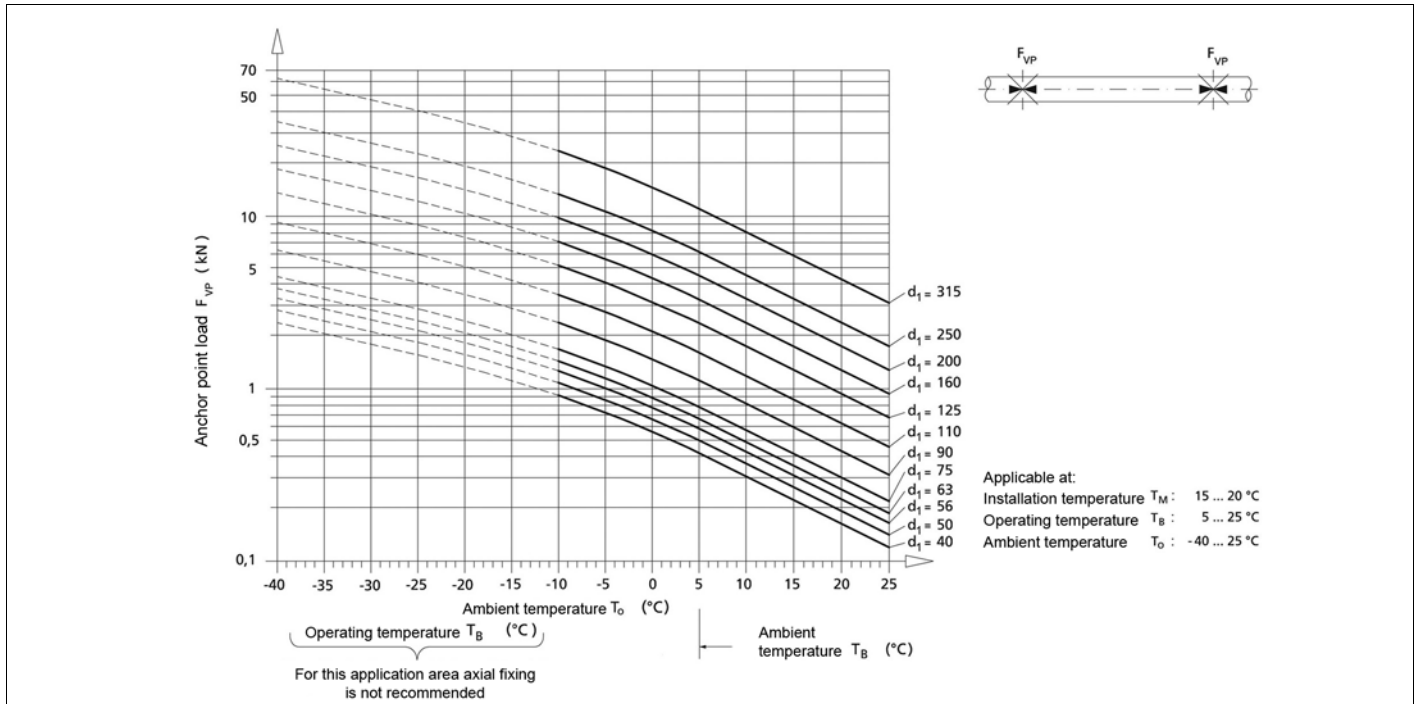

Graphic drawing 7.4 Anchor point load at ambient temperature -40°C - 25°C

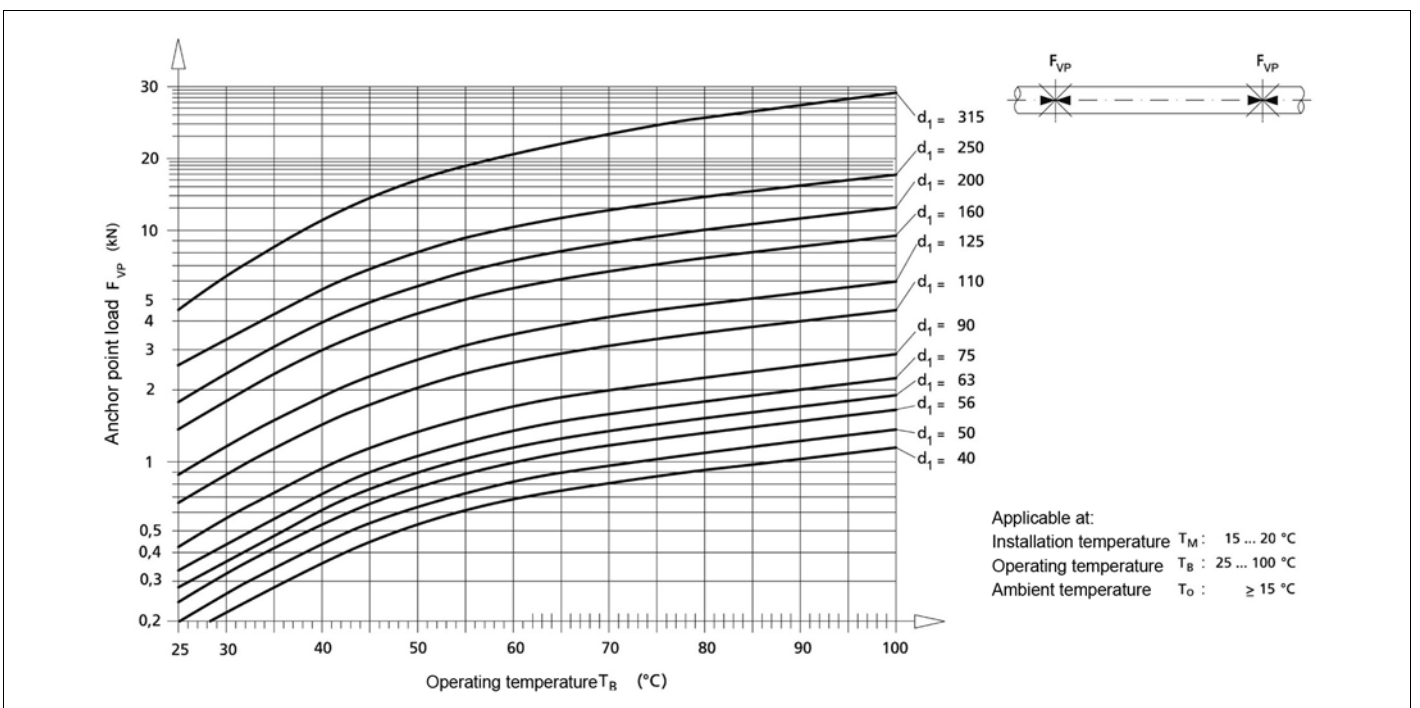

Graphic drawing 7.5 Anchor point load at ambient temperature >15°C

When applying this installation method, the following aspects need to be taken into account:

The force on the bracket depends on wall thickness and diameter of the pipe. The length of the pipe is not part of the equation. When a the pipe diameter is reduced an anchor point needs to be placed. (The occurring force can be found in graphic drawing 7.4 and 7.5). The guide brackets need to be installed between anchor points to prevent the pipe from buckling (snake effect). The bracket distances are in table 7.2. At higher temperatures the bracket distance gets smaller (table 7.1). Small diameters are recommended to be installed with support trays.

7.6 Embedding in concrete

By embedding the pipe system in concrete it acts as a rigid system. Short pipe sections can be embedded without any problem. With long pipe sections certain precautions have to be taken. There will be no connection between the concrete and the HDPE. This means that the pipe can freely contract and expand as a result of temperature changes when no precautions are taken.

To prevent the axial movement in long straight pipe sections, fittings like the Akafusion coupler can be installed to serve as an anchor point. As an alternative for the installation of anchor points snap-expansion sockets can be used. They act as an anchor point on one side and absorb the expansion on the other side of the socket. The snap-expansion socket can accommodate the expansion and contraction of a 5 m pipe.

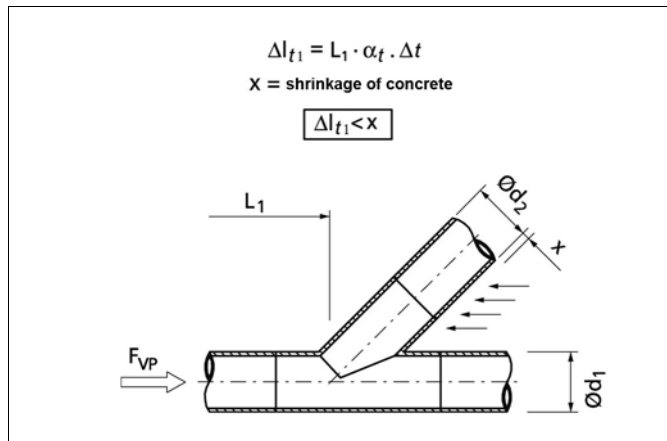

Illustration 7.5

All fittings installed in the pipe system act as an anchor point and are subdued to the expansion force.

The following precautions have to be taken when installing 45° and 88,5° branches.

When the length change is smaller than the shrinkage of the concrete no special precautions have to be taken (see illustration 7.5). This is very rarely the case.

A branch is subdued to the expansion force F_{FP} . This force and a possible deformation of the fitting can be counteracted by installing an Akafusion coupler (see illustration 7.6) or two snap-expansion sockets (see illustration 7.7).

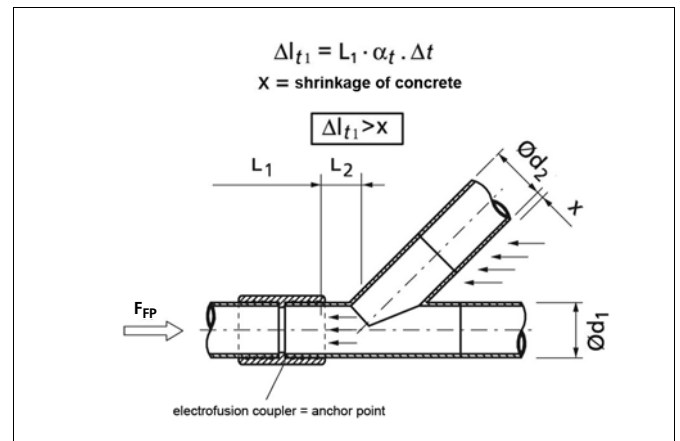

Illustration 7.6

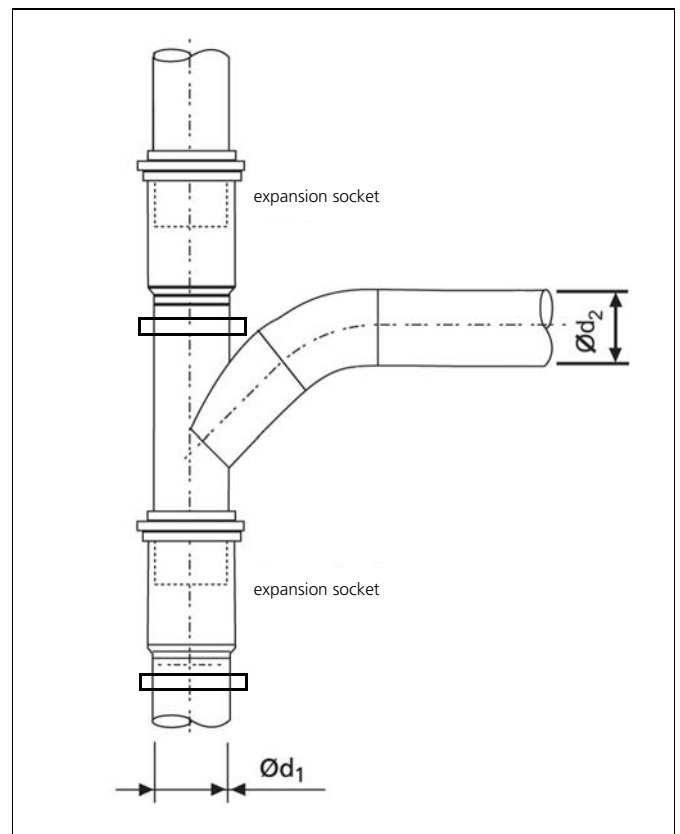

Illustration 7.7

Pipe fixing system

Both the Akafusion coupler and snap-expansion socket act as an anchor point preventing the additional load to be transferred to the branch. When the length of the branch is more than 2 m special precautions have to be taken there as well.

A fitting installed in a ceiling penetration acts as an anchor point as well. In case branches are used in this place it is recommended to use an Akafusion coupler for the jointing and embed this coupler in the concrete as well.

7.7 Underground HDPE drainage pipes

Due to specific properties such as flexibility and resistance to cold temperature (freezing), HDPE pipe systems are ideal for use in underground pipe-lines. Buried pipes are exposed to various loads. It is, in effect, the stability of Akatherm HDPE in withstanding these pressures that makes it possible to lay the pipes at substantial depth. The suitability depends on such factors as depth, groundwater level, density of the soil and traffic load.

7.7.1 Loads

Soil and traffic loads

The load capacity of underground plastic pipes is based on changes in the pipe and movement of the ground. The soil load causes the top of the pipe to deflect downward. The sides of pipe are correspondingly pressed outward against the surrounding soil. The reaction pressure, the lateral force exercised on the pipe, prevents a larger cross-sectional deformation (support function). The construction of the trench, the type of bedding used and the backfilling of the trench are, to a large extent, decisive factors determining the load capacity of an underground plastic pipe. The load needs to be evenly distributed over the entire pipeline. For this reason, the trench must be created in such a manner that bends in a longitudinal direction and loads at specific points are avoided.

It is assumed that the increased pressure resulting from traffic loads caused by road or rail traffic are surface loads evenly distributed over the pipe sectional plane.

Groundwater

Underground pipes can be subject to external overpressure, especially in areas with high groundwater levels. In addition, a pipe enclosed in concrete is exposed to external pressure, though just for a short period. Underground pipe systems subject to additional external pressure must be tested for the ability to withstand denting. The effective load due to external pressure will agree with the related hydrostatic pressure on the pipe axis.

For special circumstances, request assistance from our Technical Support department.

7.7.2 Construction and installation of underground pipe systems

Trench base (bedding) - zone 1

The state and form of the trench base must match the mechanical properties of the thermoplastic pipe. The existing or newly constructed support layer must consist of stone-free sand that has been slightly compressed using a suitable piece of equipment. The pipe must be laid in such a way that a stable surface with at least a 90° arc of enclosure is created in order to prevent sagging or intermittent loads.

The trench in which the pipe is laid must be sufficiently narrow in order to keep the final soil pressure as low as possible. The space between pipe and trench wall must be at least 100 mm.

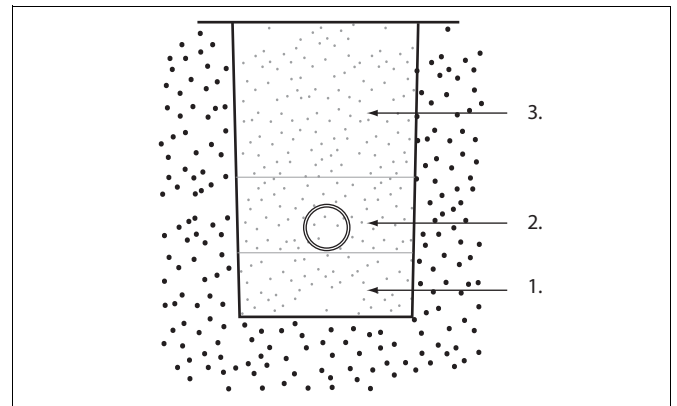

Illustration 7.8

The height of zone 1 depends on the soil conditions and the nominal pipe width, and is computed using the following equation.

$$H_{so} = H_m + \frac{DN}{10}$$

Equation 7.3

- H_{so} = height of the soil in zone 1 (mm)
- H_m = minimum initial thickness
normal soil conditions: 100 mm
rocky or thick soil: 150 mm
- DN = nominal pipe width (mm)

Embedding of the pipe (Consolidation) - zone 2

The fill for the pipe system embedding must consist of stone-free sand or similar material: the fill must ensure optimal compacting of the ground. The embedding is, to a large extent, a decisive factor in distributing the soil pressure and load, as well as providing lateral soil pressure on the pipe with the resulting unburdening effect.

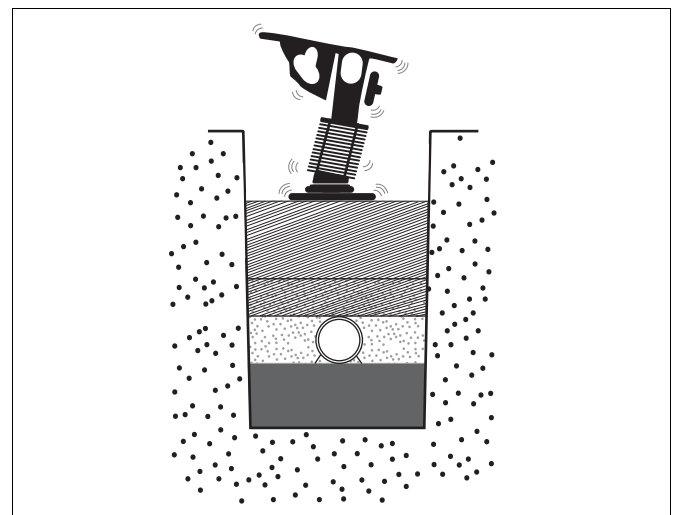

Illustration 7.9

The height of zone 2 must extend to at least 150 mm above the pipe. This must also be at least 100 mm above any pipe fittings.

Filling of trench (Protective layer) - zone 3

The trench is backfilled in layers and compacted. Types of soil and materials that can cause dents may not be used to backfill the trench (e.g. ash, waste, stones). The use of heavy compacting equipment to compact the soil is not permissible for soil layers <1,0 m. The required thickness of zone 3 depends on trench form and pipe-wall thickness. Our Technical Support department can advise you in this regard.

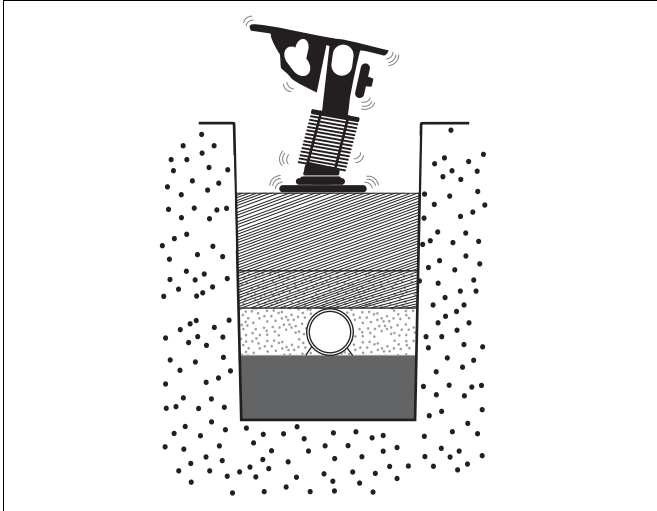

Illustration 7.10

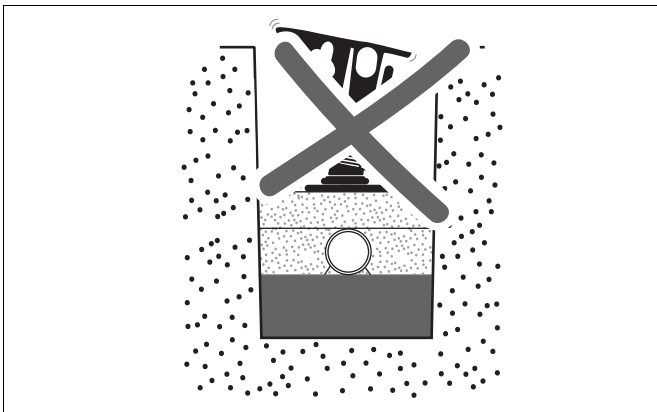

Illustration 7.11

Due to the risk of the waste water freezing, the pipes must be laid at a frost-free depth.